

# PC3-PFHF

PC3-PFHF-70G-3M-1PH-220

- Diesel fuel cart with bag housing pre-filter (for removal of microbial bloom contamination and rust), particulate filter, and high efficiency coalescing filter (for single-pass removal of emulsified and free water), and pump/motor combo 70 GPM (220V Single Phase)
- Perfect for kidney loop polishing or single pass transfer of diesel fuel in larger storage tanks
- All-aluminum filter housing is fully compatible with diesel and biodiesel blends
- Uses Proprietary **GeoDry** and **PureFuel** element technology which exceed SAEJ1488 requirements

## Bulk Diesel Portable Skid #7645503

|                                      |   |
|--------------------------------------|---|
| Flow Rating:                         | 70 gpm or 140 gpm                                     |
| Temp. Range:                         | 32° to 150°F (No Heater)                              |
| Bypass Indication PFHF:              | 15 psi  |
| GDHF Bypass Indication/<br>Cracking: | 25 psi/30 psi   |
| PFHF Bypass Indication/<br>Cracking: | 15 psi/20 psi   |
| Porting Base:                        | Anodized Aluminum                                     |
| Pre-Filter Bag Housing:              | 304 Stainless   |
| GDHF & PFHF:                         | Aluminum w/ Epoxy Paint<br>Electroless Nickel Plating |
| PFHF Element Change<br>Clearance:    | 36" Min.  |
| GDHF Element Change<br>Clearance:    | 34" Min.  |
| Full Load Motor Amps:                | 13.0 A @ 460V (2x 6.5A -<br>5 HP Motors)              |
| Motor Voltage (Frequency):           | 460 VAC (60 Hz) - 3<br>Phase                          |
| Service Factor Amp:                  | 1.0 SF at 40° C (104°F)                               |

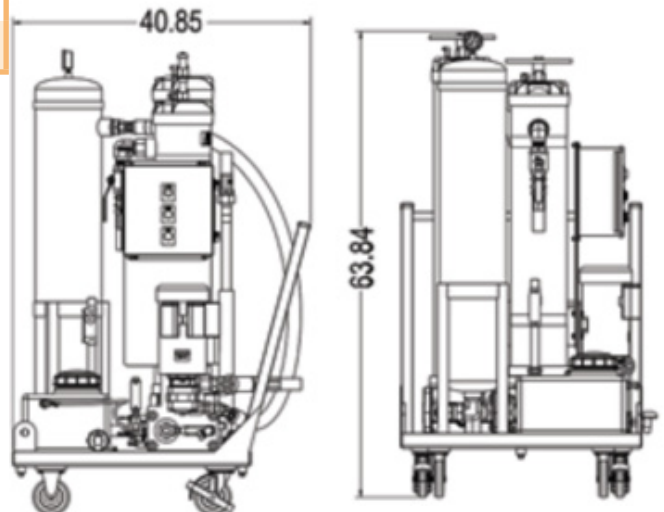
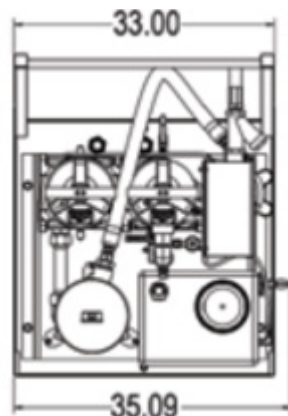

PureFuels Spare Element #7645513  
PF-70G-3M

PureFuels Spare Bags #7631446  
PEF25P2PH - 25µ Polyfelt media  
(Sold in Qty 50 Only)

GeoDry Spare Element #7645514  
GDF-70G-1M